



# Troubleshooting

To better help our customers - this HP LaserJet 2200 series troubleshooting page is simply a guide / additional information for your convenience, as you search for assistance in repairing your machine. Although this information is provided for your convenience it is recommended, for the most part, that a technician inspects your office equipment.

It is recommended to consult with a professional when ordering your printer part(s).

## Chapter contents

Troubleshooting with control-panel messages  
Control panel lights  
Control-panel light messages

Shop with us while you troubleshoot.

- \* HP oem parts
- \* HP LaserJet maintenance kits
- \* Toners for your printer
- \* HP fuser assembly units
- \* HP fuser kit 110v & 220v
- \* Parts assemblies for printers
- \* Service maintenance parts
- \* Color laserJet printers
- \* LaserJet printers and parts
- \* Hard to find officejet parts
- \* Hard to find deskjet parts

User-friendly [SmartSearch!](#)

# Troubleshooting with control-panel messages

## Control panel lights

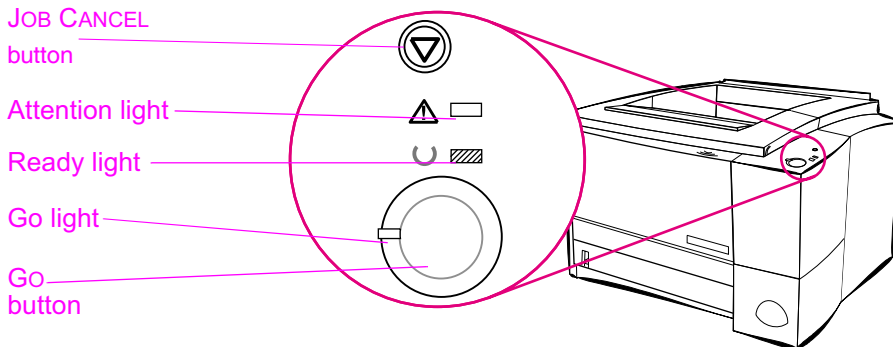


Figure 155. Control panel layout

## Control-panel light messages

Light patterns provide status and error messages. The lights can be in any one of the following states:



Figure 156. Light states

The following control-panel light patterns indicate various conditions of the printer in preparation for, or during, printing. If the Attention light is blinking, the printer is experiencing an error. The messages are grouped according to error type: status, attendance, continuable, fatal, and accessory errors. In many cases the error provides specific information about the defective component.

If the printer lights indicate a continuable, fatal, or accessory error, press **GO** and **JOB CANCEL** simultaneously to display additional error information. The lights flash briefly to indicate transitions in error states before displaying the next pattern.





See "Continuable, fatal, and accessory errors" page 184 for secondary information about each of these three types of errors.

---

### Note

Secondary information about 79 fatal errors (unrecoverable firmware errors) is not included in the scope of this document. If a 79 fatal error occurs, replace the formatter.


**Table 27. Primary status codes**

Control-panel light pattern	Primary status message	Recommended action
	<p>Start-up. The Go, Ready, and Attention lights cycle one after another.</p>	<ul style="list-style-type: none"> <li>No action is needed.</li> </ul> <p><b>Note</b> Pressing <b>Go</b> or <b>JOB CANCEL</b> has no effect until the printer is ready.</p>
	<p>Ready. The Ready light is on and the printer is ready to print.</p>	<ul style="list-style-type: none"> <li>No action is needed.</li> </ul> <p><b>Note</b> Pressing <b>Go</b> prints a demo page.</p>
	<p>Processing. The printer is receiving or processing data.</p>	<ul style="list-style-type: none"> <li>No action is needed.</li> </ul> <p><b>Note</b> Pressing <b>JOB CANCEL</b> cancels the current job. One or two pages might print as the printer clears the print job. The printer returns to the ready state after the job is cancelled.</p>
	<p>Attention. The printer requires attention for one of the following reasons:</p> <ul style="list-style-type: none"> <li>- a door is open</li> <li>- the toner cartridge is missing</li> <li>- print media is jammed in the printer</li> <li>- media supply is depleted</li> </ul>	<ul style="list-style-type: none"> <li>Pressing <b>Go</b> causes the printer to attempt to clear the jam. It might be necessary to clear the jam manually and push <b>Go</b> or close the top cover.</li> </ul>



## Continuable, fatal, and accessory errors

Additional information in the form of a secondary error message is available for each of the following three types of errors. The first entry in each of the following tables shows the primary error light pattern. The remaining entries illustrate the secondary error messages. The tables also contain information that typically appears in the status log area of the self test/configuration page.





**Table 28. Continuable attention error codes**

Control-panel light pattern	Continuable attention error message	Status log code	Recommended action
	Continuable error or tray 1 is out of paper. Pressing <b>Go</b> causes the printer to attempt to recover from the error and print whatever it can. If the recovery is unsuccessful, the printer will return to the continuable error state.		<ul style="list-style-type: none"> <li>Press <b>Go</b> to attempt an error recovery and continue printing.</li> <li>If the error persists, press <b>Go</b> and <b>JOB CANCEL</b> simultaneously to view the secondary continuable error information. See table 29, "Continuable attention error secondary codes" on page 184.</li> </ul>



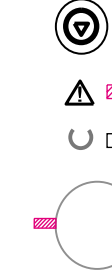
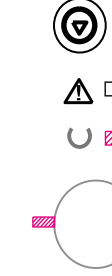
**Table 29. Continuable attention error secondary codes**

Control-panel light pattern	Continuable attention error secondary message	Status log code	Recommended action
	General continuable error		<ul style="list-style-type: none"> <li>Verify that all of the power-supply wire harness connections are connected correctly and fully seated.</li> <li>Replace the formatter PCB.</li> <li>Replace the engine controller.</li> </ul>
	Memory overflow/memory full (20)	30016	<ul style="list-style-type: none"> <li>The printer memory is full. Press <b>Go</b> to resume printing. If you lose some data, try to free some printer memory by removing any unnecessary fonts, macros, or any other data currently in the printer memory. If you continue to lose data, you might need to add more printer memory. For a temporary solution, simplify the image or print at a lower resolution.</li> </ul>

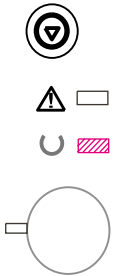


**Table 29. Continuable attention error secondary codes (continued)**

Control-panel light pattern	Continuable attention error secondary message	Status log code	Recommended action
	Temporary engine error (41.x)	30034	<ul style="list-style-type: none"> <li>● Press <b>GO</b>. The page containing the error will be printed.</li> <li>● If the error persists, reseal the connections to the laser/scanner, formatter, and engine controller.</li> <li>● Replace the laser/scanner.</li> <li>● Replace the formatter.</li> <li>● Replace the engine controller.</li> </ul>
	Print overrun (21)	30017	<ul style="list-style-type: none"> <li>● The print job was too complex for available printer memory. Press <b>GO</b> to resume printing. If you lose some data, you might need to add more printer memory. For a temporary solution, simplify the image or print at a lower resolution.</li> </ul>
	Buffer flow error (22)	30027	<ul style="list-style-type: none"> <li>● Verify that the printer cable is connected properly and fully seated at connections. Always use a high-quality cable. Some non-HP cables might be missing pin connections, or might otherwise not conform to IEEE-1284 specifications.</li> <li>● Replace the formatter</li> </ul>
	Bad connection (40)	30018	<ul style="list-style-type: none"> <li>● The connection between the printer and the EIO card is bad.</li> <li>● Press <b>GO</b> to clear the error message and continue printing.</li> <li>● If the error message persists, turn the printer off and reset the EIO card. Turn the printer on.</li> <li>● Replace the EIO card.</li> </ul>


**Table 29. Continuable attention error secondary codes (continued)**

Control-panel light pattern	Continuable attention error secondary message	Status log code	Recommended action
	NVRAM error (68)	30035 or 30036	<ul style="list-style-type: none"> <li>● A memory error resulted in one or more printer settings being reset to factory defaults.</li> <li>● Print a configuration page and verify that the printer settings are set correctly.</li> <li>● Turn the printer off. Press and hold <b>JOB CANCEL</b> and turn the printer on. Keep <b>JOB CANCEL</b> depressed until all of the Control-panel lights illuminate. Release <b>JOB CANCEL</b> and send the print job again.</li> <li>● Replace the formatter.</li> </ul>
	I/O error (81)		<ul style="list-style-type: none"> <li>● The EIO accessory has encountered a critical error.</li> <li>● Turn the printer off and then on.</li> <li>● If the error message persists, turn the printer off and reset the EIO card. Turn the printer on.</li> <li>● Replace the EIO card.</li> </ul>
	Memory configuration error		<ul style="list-style-type: none"> <li>● Perform a “cold reset”.</li> </ul> <p><b>Note</b> If both the Attention and Ready lights come on before you release <b>GO</b>, then you must repeat the procedure.</p> <ul style="list-style-type: none"> <li>● If the error persists, remove or replace DIMM(s).</li> <li>● Replace the formatter.</li> </ul>
	Personality or job-related error	30076	<ul style="list-style-type: none"> <li>● Perform a “cold reset”.</li> </ul> <p><b>Note</b> If both the Attention and Ready lights come on before you release <b>GO</b>, then you must repeat the procedure.</p> <ul style="list-style-type: none"> <li>● If the error persists, remove or replace language DIMM.</li> <li>● Replace the formatter.</li> </ul>






**Table 29. Continuable attention error secondary codes (continued)**

Control-panel light pattern	Continuable attention error secondary message	Status log code	Recommended action
	EIO port error		<ul style="list-style-type: none"> <li>Turn the printer off and reseal the EIO accessory. Turn the printer on.</li> <li>Replace the formatter.</li> </ul>
	DIMM slot 1 incompatible error		<ul style="list-style-type: none"> <li>Turn the printer off. Reseat DIMM 1. Turn the printer on.</li> <li>If the problem persists, replace DIMM 1.</li> <li>Replace the formatter.</li> </ul>
	DIMM slot 2 incompatible error		<ul style="list-style-type: none"> <li>Turn the printer off. Reseat DIMM 2. Turn the printer on.</li> <li>If the problem persists, replace DIMM 2.</li> <li>Replace the formatter.</li> </ul>






**Table 30. Fatal error codes**

Control-panel light pattern	Fatal error message	Status log code	Recommended action
	The printer has experienced an error and cannot recover. All the lights are on.		<ul style="list-style-type: none"> <li>View the fatal error secondary codes.</li> <li>To clear the error, turn the printer off, and then turn it on. If the error persists, turn the printer off for 15 minutes and then turn it on.</li> </ul> <p><b>Note</b> Pressing <b>GO</b> and <b>JOB CANCEL</b> shows the fatal secondary error codes.</p>



**Table 31. Fatal error secondary codes**

Control-panel light pattern	Fatal error secondary message	Status log code	Recommended action
	General fatal error (79)		<ul style="list-style-type: none"> <li>● Turn power off and back on.</li> <li>● If the error persists, turn off power. Remove all accessories (for example DIMM, EIO card). Turn on the printer.</li> <li>● Replace the formatter.</li> <li>● Replace the engine controller.</li> <li>● Replace the power supply.</li> </ul>
	Engine communication error (55)	40055	<ul style="list-style-type: none"> <li>● A printer error has occurred. Press <b>Go</b> to clear the error message.</li> <li>● Check the connections to the formatter and the engine controller Assembly.</li> <li>● Replace the formatter.</li> <li>● Replace the engine controller.</li> <li>● Replace the power supply.</li> </ul>
	Scanner error (52)	40052	<ul style="list-style-type: none"> <li>● Press <b>Go</b>. The page containing the error will automatically be reprinted.</li> <li>● Turn the printer off and reseal the laser scanner cables.</li> <li>● Replace the laser scanner.</li> </ul>
	Bad beam detect error (51)	40051	<ul style="list-style-type: none"> <li>● Press <b>Go</b>. The page containing the error will automatically be reprinted.</li> <li>● Turn the printer off and reseal the laser scanner cables.</li> <li>● Replace the laser/scanner.</li> </ul>
	Scan motor error (57)	40057	<ul style="list-style-type: none"> <li>● Turn power off and back on.</li> <li>● If the error persists, turn the printer off, reseal the connection between the laser scanner assembly and the engine controller. Turn the printer on.</li> <li>● Replace the laser/scanner.</li> <li>● Replace the engine controller.</li> </ul>


**Table 31. Fatal error secondary codes (continued)**

Control-panel light pattern	Fatal error secondary message	Status log code	Recommended action
	Bad fuser error (50)	40050	<ul style="list-style-type: none"> <li>● Be sure that the fuser is installed correctly and is fully seated.</li> <li>● Reseat the fuser cables.</li> <li>● Replace the fuser.</li> <li>● Replace the engine controller assembly.</li> <li>● Replace the power supply.</li> </ul>
	Formatter internal RAM or ROM error		<ul style="list-style-type: none"> <li>● Turn the printer off, then turn it back on.</li> <li>● Replace the formatter.</li> </ul>
	Fan motor error (58)	40058	<ul style="list-style-type: none"> <li>● Turn the printer off, then turn it back on.</li> <li>● Turn the printer off, then reseal the connection between the fan and the formatter.</li> <li>● Replace the fan.</li> <li>● Replace the engine controller assembly.</li> </ul>
	NVRAM error (68)		<ul style="list-style-type: none"> <li>● Turn the printer off, then turn it back on.</li> <li>● Replace the formatter.</li> </ul>
	Scan buffer error (64)	40064	<ul style="list-style-type: none"> <li>● Turn the printer off, then turn it back on.</li> <li>● If the message persists, replace the formatter.</li> </ul>


**Table 31. Fatal error secondary codes (continued)**

Control-panel light pattern	Fatal error secondary message	Status log code	Recommended action
	RAM controller error (65)	40065	<ul style="list-style-type: none"> <li>● Turn the printer off, then turn it back on.</li> <li>● Replace the formatter.</li> </ul>
	Miscellaneous interface hardware error (67)	40067	<ul style="list-style-type: none"> <li>● Check the I/O connections.</li> <li>● Verify that the cable is IEEE-1284 compliant (if applicable).</li> </ul>


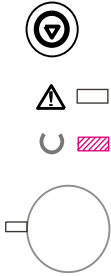
**Table 32. Accessory error codes**

Control-panel light patterns	Accessory error message	Status log code	Recommended action
	An error has occurred with either the EIO port or the DIMM (memory) slots.		<ul style="list-style-type: none"> <li>● Press <b>GO</b> and <b>JOB CANCEL</b> simultaneously to view the secondary information. See table 29, "Continuable attention error secondary codes" on page 184 and table 33, "Accessory errors secondary codes" on page 190.</li> </ul>

**Table 33. Accessory errors secondary codes**

Control-panel light patterns	Accessory secondary error message	Status log code	Recommended action
	EIO port error		<ul style="list-style-type: none"> <li>● Turn the printer off and reseal the EIO accessory. Turn the printer on.</li> <li>● Replace the formatter.</li> </ul>

**Table 33. Accessory errors secondary codes**

Control-panel light patterns	Accessory secondary error message	Status log code	Recommended action
	DIMM slot 1 incompatible error		<ul style="list-style-type: none"> <li>● Turn the printer off. Reseat DIMM in slot 1. Turn the printer on.</li> <li>● If the problem persists, replace DIMM in slot 1.</li> <li>● Replace the formatter.</li> </ul>
	DIMM slot 2 incompatible error		<ul style="list-style-type: none"> <li>● Turn the printer off. Reseat DIMM in slot 2. Turn the printer on.</li> <li>● If the problem persists, replace DIMM in slot 2.</li> <li>● Replace the formatter.</li> </ul>